

RoHS HF REACH

|                               |                    |
|-------------------------------|--------------------|
| 2/3" F1.6/50MM /5MEGA/C MOUNT |                    |
| FOCAL LENGTH                  | f=50MM             |
| F.NO                          | F=1:1.6--16        |
| FOCUS DISTANCE                | 0.1M---0.4M        |
| FLANGE BACK                   | 17.526MM IN AIR    |
| BACK FOCUS                    | 30                 |
| FILTER SCREW SIZE             | M30.5*P0.5         |
| MOUNT                         | C                  |
| REL. ILLUMINATION             | ≥80%               |
| Front/Rear Effective Dia      | Front φ18 Rear φ13 |

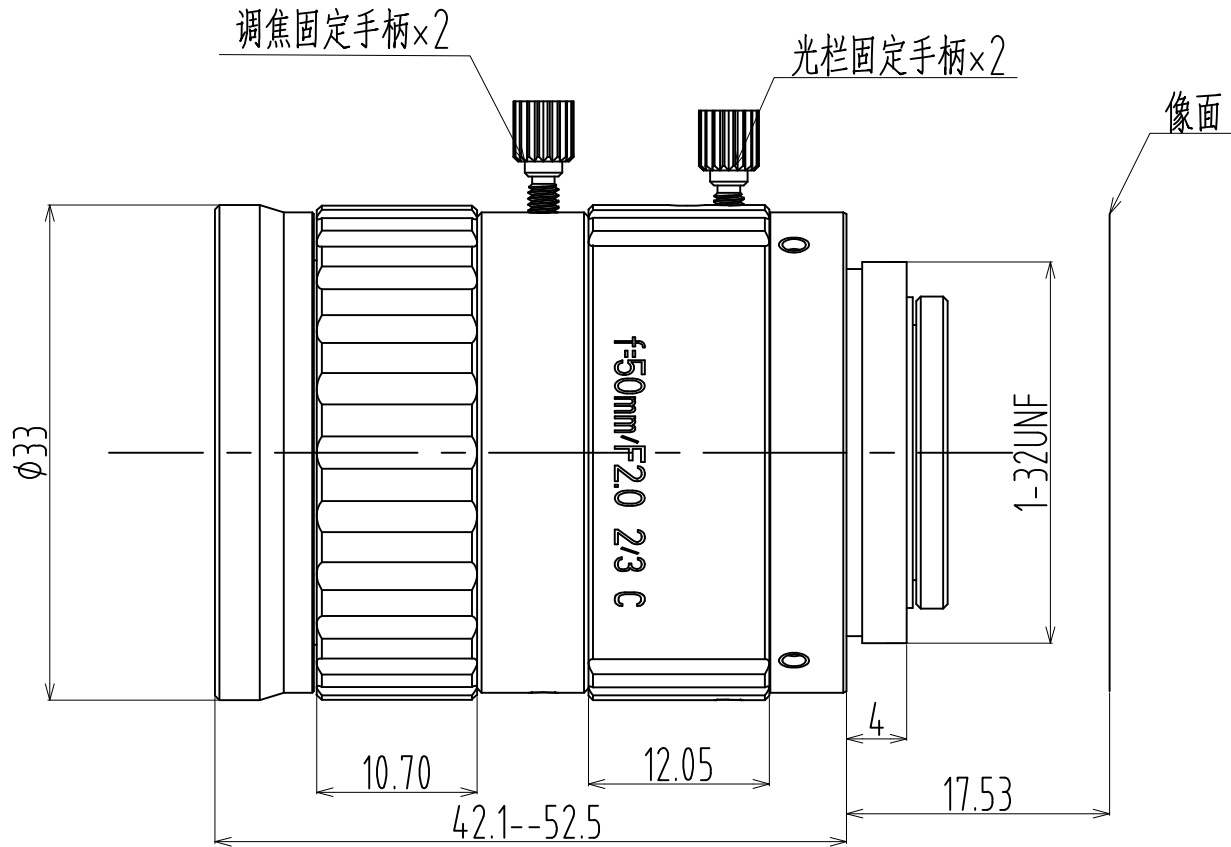

|               |        |       |       |       |
|---------------|--------|-------|-------|-------|
| FIELD OF VIEW | SENSOR | 2/3"  | 1/2"  | 1/3"  |
|               | D      | 21.3° | 15.6° | 11.9° |
|               | H      | 17°   | 12.5° | 9.5°  |
|               | V      | 12.8° | 9.4°  | 7.1°  |

|               |        |        |        |
|---------------|--------|--------|--------|
| TV DISTORTION | <0.05% | <0.03% | <0.02% |
|---------------|--------|--------|--------|

|                  |                       |                             |   |
|------------------|-----------------------|-----------------------------|---|
| WORKING DISTANCE | OPTICAL MAGNIFICATION | 2/3" FIELD OF VIEW 需搭配接圈表选型 |   |
| MM               |                       | H                           | V |

|     |        |        |        |
|-----|--------|--------|--------|
| 300 | 0.208X | 42.788 | 32.091 |
| 280 | 0.225X | 39.528 | 29.646 |
| 250 | 0.256X | 34.649 | 25.987 |
| 240 | 0.269X | 33.026 | 24.769 |
| 230 | 0.282X | 31.405 | 23.554 |
| 220 | 0.298X | 29.787 | 22.34  |
| 210 | 0.315X | 28.172 | 21.129 |
| 200 | 0.334X | 26.56  | 19.92  |
| 190 | 0.355X | 24.952 | 18.714 |
| 170 | 0.408X | 21.752 | 16.314 |
| 150 | 0.478X | 18.578 | 13.933 |
| 130 | 0.575X | 15.445 | 11.584 |
| 120 | 0.64X  | 13.900 | 10.425 |
| 110 | 0.719X | 12.372 | 9.279  |
| 100 | 0.820X | 10.858 | 8.413  |

|                     |            |
|---------------------|------------|
| 外观标准                | 60--40     |
| WORKING TEMPERATURE | -40°C~80°C |
| STORAGE TEMPERATURE | -40°C~85°C |

备注：1 此镜头为50mm微距  
2.工作距离可以加接圈调整

|                  |       |        |             |         |          |
|------------------|-------|--------|-------------|---------|----------|
| Common Tolerance |       | ④      |             |         |          |
| Angle            | ±0.5° | ③      |             |         |          |
| 0.000            | ±0.01 | ②      |             |         |          |
| 0.00             | ±0.03 | ①      |             |         |          |
| 0.0              | ±0.05 | Rev    | Description | Name    | Date     |
| 0                | ±0.1  | Design | Examine     | Checked | Approved |

|                 |  |                       |        |
|-----------------|--|-----------------------|--------|
| Material:       |  | 3RD_ANGLE_PROJN       | Model: |
| /               |  |                       |        |
| Cnomax Vision   |  | 三分之二英寸微距50MM-5M       |        |
| Unit mm         |  | Part Name: M-CNV505MP |        |
| Scale 2:1       |  | Dwg No:               |        |
| Ver 00          |  |                       |        |
| Date 2019.10.28 |  |                       |        |