

RoHS HF REACH

| | |
|-------------------------------|--------------------------------|
| 2/3" F1.6/35MM /5MEGA/C MOUNT | |
| FOCAL LENGTH | f=35MM |
| F.NO | F=1:1.6--16 |
| FOCUS DISTANCE | 0.08M---0.3M |
| FLANGE BACK | 17.526MM IN AIR |
| BACK FOCUS | 8.44 |
| FILTER SCREW SIZE | M30.5*P0.5 |
| MOUNT | C |
| REL. ILLUMINATION | ≥60% |
| Front/Rear Effective Dia | Front ϕ 19 Rear ϕ 17 |

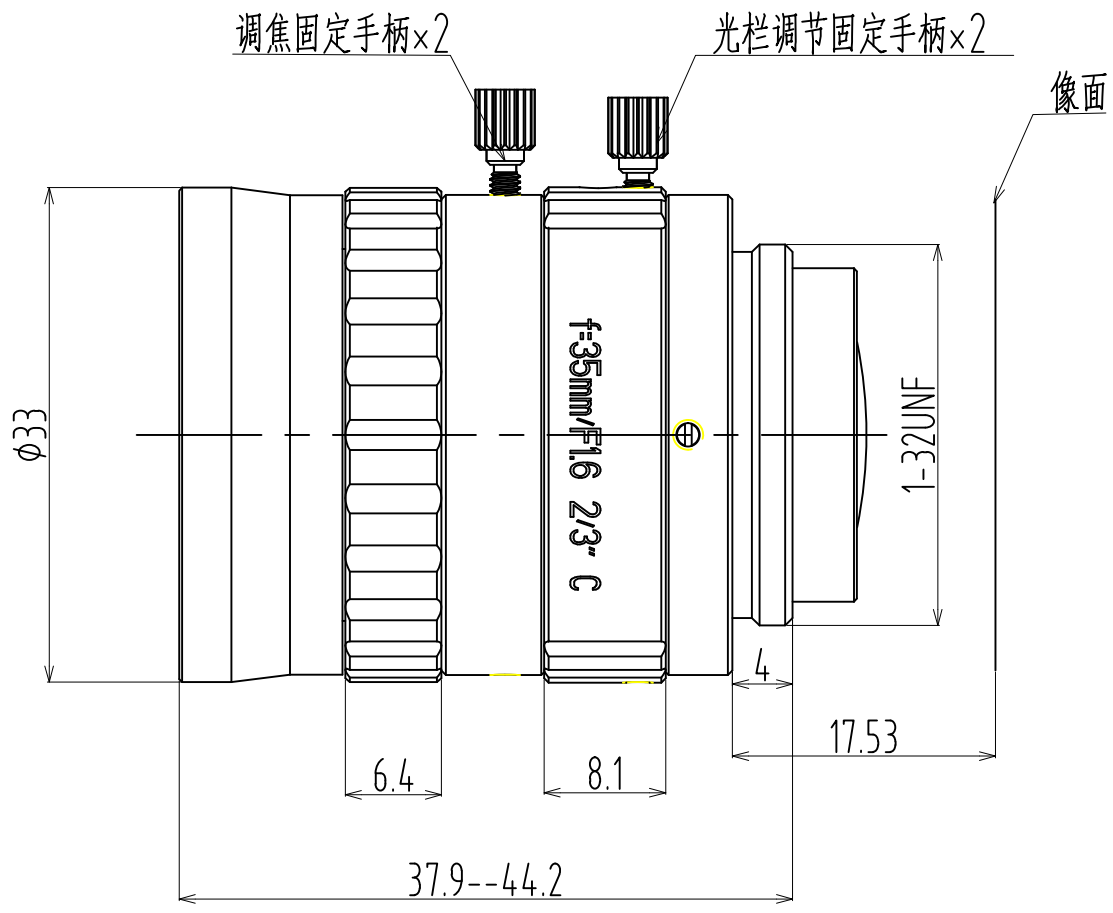

| | | | | |
|---------------|--------|--------|--------|--------|
| FIELD OF VIEW | SENSOR | 2/3" | 1/2" | 1/3" |
| | D | 40.1° | 29° | 21.8° |
| | H | 32.1° | 23.2° | 17.4° |
| | V | 24.1° | 17.4° | 13.1° |
| TV DISTORTION | | <0.05% | <0.03% | <0.02% |

| | | | |
|------------------|-----------------------|----------------------------|--------|
| WORKING DISTANCE | OPTICAL MAGNIFICATION | 2/3" FIELD OF VIEW 需搭配接圈选型 | |
| MM | | H | V |
| 220 | 0.182X | 47.5 | 35.73 |
| 210 | 0.191X | 45.8 | 34.5 |
| 200 | 0.202X | 44.014 | 33.011 |
| 190 | 0.210X | 42.31 | 31.73 |
| 180 | 0.218X | 40.6 | 30.455 |
| 170 | 0.228X | 38.894 | 29.17 |
| 160 | 0.238X | 37.188 | 27.89 |
| 150 | 0.249X | 35.48 | 26.61 |
| 140 | 0.262X | 33.78 | 25.33 |
| 130 | 0.276X | 32.074 | 24.055 |
| 120 | 0.292X | 30.37 | 22.778 |
| 110 | 0.309X | 28.688 | 21.501 |
| 100 | 0.328X | 26.967 | 20.225 |
| 90 | 0.035X | 25.267 | 18.95 |
| 80 | 0.376X | 23.596 | 17.677 |

| | | | | | |
|---------------------|------------|-----|--------|--------|--------|
| 外观标准 | 60--40 | 100 | 0.328X | 26.967 | 20.225 |
| WORKING TEMPERATURE | -40°C~80°C | 90 | 0.035X | 25.267 | 18.95 |
| STORAGE TEMPERATURE | -40°C~85°C | 80 | 0.376X | 23.596 | 17.677 |

备注：1 此镜头为35mm微距
2.工作距离可以加接圈调整

| | | | | | | |
|------------------|-------|-----|-------------|---------|---------|----------|
| Common Tolerance | | ④ | | | | |
| Angle | ±0.5° | ③ | | | | |
| 0.000 | ±0.01 | ② | | | | |
| 0.00 | ±0.03 | ① | | | | |
| 0.0 | ±0.05 | Rev | Description | Name | Date | |
| 0 | ±0.1 | | Design | Examine | Checked | Approved |

| | | | |
|-----------|------------|-----------------|--------|
| Material: | | 3RD_ANGLE_PROJN | Model: |
| / | | | |
| Unit | mm | Part Name: | |
| Scale | 2:1 | M-CNV355MP | |
| Ver | 00 | Dwg No: | |
| Date | 2019.10.28 | | |