

RoHS HF REACH

调焦固定螺丝 (整周2个)

像面

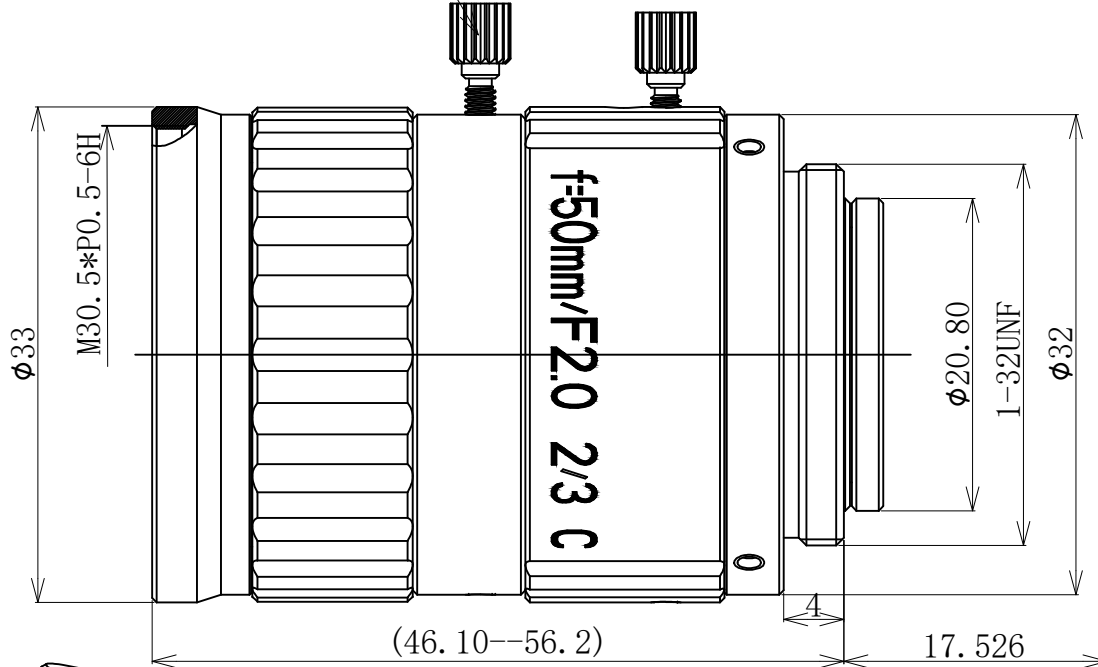

2/3" F1.6/50MM /5MEGA/C MOUNT					
FOCAL LENGTH		f=50MM			
F.NO		F=1:2.0--16			
FOCUS DISTANCE		0.3M--INF.			
FLANGE BACK		17.526MM IN AIR			
BACK FOCUS		10.88MM IN AIR			
FILTER SCREW SIZE		M30.5*P0.5			
MOUNT		C			
REL. ILLUMINATION		≥76%			
CHIEF RAY ANGLE		<3°			
FIELD OF VIEW	SENSOR	2/3"	1/2"		
	D	13.2°	9.6°		
	H	10.6°	7.7°		
	V	8°	5.8°		
TV DISTORTION		<0.05%			
WORKING DISTANCE	OPTICAL MAGNIFICATION	2/3" FIELD OF VIEW			
		MM	H	V	
1100	0.044	201.51	151.13		
1000	0.048	182.57	136.93		
900	0.054	163.65	122.74		
850	0.057	154.2	115.65		
800	0.061	144.74	108.56		
750	0.065	135.29	101.47		
700	0.07	125.85	94.386		
650	0.076	116.41	87.306		
600	0.083	106.97	80.229		
550	0.091	97.542	73.157		
500	0.1	88.116	66.087		
450	0.112	78.692	59.019		
400	0.128	69.266	51.949		
WORKING TEMPERATURE	-40°C~80°C	350	0.148	59.826	44.87
STORAGE TEMPERATURE	-40°C~85°C	300	0.176	50.352	37.764

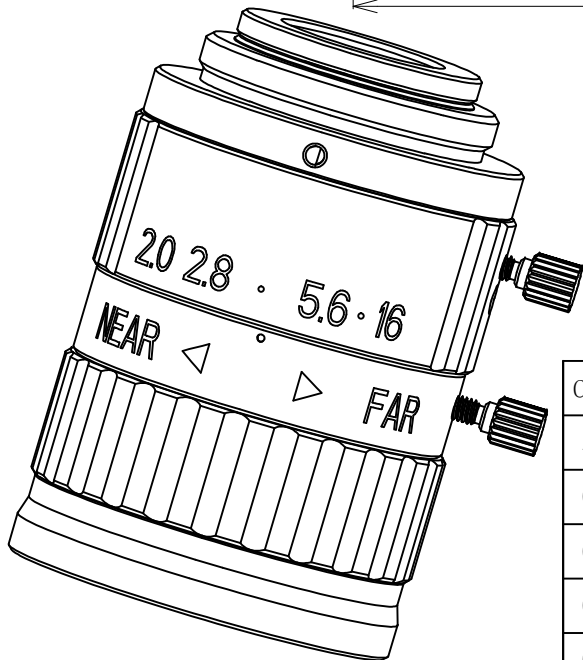

外观标准	60--40	400	0.128	69.266	51.949
WORKING TEMPERATURE	-40°C~80°C	350	0.148	59.826	44.87
STORAGE TEMPERATURE	-40°C~85°C	300	0.176	50.352	37.764

Common Tolerance		④					
Angle		±0.5°	③				
0.000		±0.01	②				
0.00		±0.03	①				
0.0		±0.05	Rev	Description	Name	Date	
0		±0.1	Design	Examine	Checked	Approved	

Material:	
/	
3RD_ANGLE_PROJN	
Unit	mm
Scale	2:1
Ver	00
Date	2018.03.01

Cnomax Vision	
Model:	
三分之二英寸50MM-5M	
Part Name:	
CNV505M	
Dwg No:	