

RoHS HF REACH

2/3" F1.6/35MM /5MEGA/C MOUNT

FOCAL LENGTH	f=35MM
F.NO	F=1:1.6--16
FOCUS DISTANCE	0.15M--1.5M
FLANGE BACK	17.526MM IN AIR
BACK FOCUS	12.52MM IN AIR
FILTER SCREW SIZE	M30.5*P0.5
MOUNT	C
REL. ILLUMINATION	≥76%
CHIEF RAY ANGLE	<5°

调焦固定螺丝 (整周2个)

光栏调节固定螺丝 (整周2个)

像面

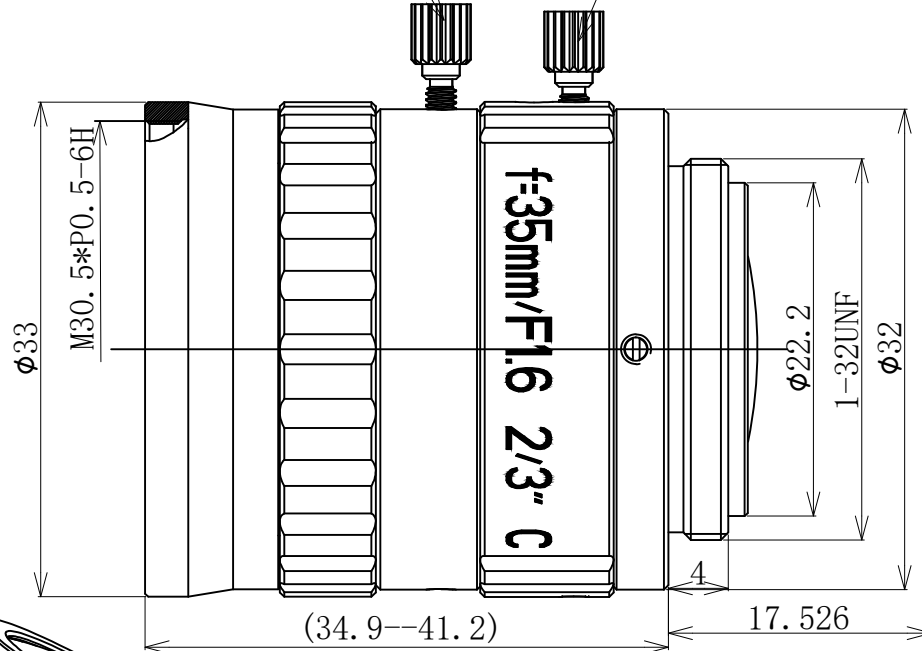

FIELD OF VIEW	SENSOR	2/3"	1/2"
	D	17.3°	12.5°
	H	13.7°	10°
	V	10.2°	7.3°
TV DISTORTION		<0.15%	<0.1%

WORKING DISTANCE	OPTICAL MAGNIFICATION	2/3" FIELD OF VIEW	
MM		H	V

900	0.038	232.7	147.53
800	0.043	207.87	155.9
750	0.045	195.45	146.59
700	0.048	183.03	137.27
650	0.052	170.61	127.96
600	0.056	158.19	118.64
550	0.061	145.77	109.33
500	0.066	133.35	100.01
450	0.073	120.92	90.963
400	0.082	108.5	81.375
350	0.092	96.072	72.054
300	0.106	83.641	62.731
250	0.124	71.206	53.404
200	0.151	58.762	44.071
150	0.191	46.304	34.728

外观标准	60--40	250	0.124	71.206	53.404
WORKING TEMPERATURE	-40°C~80°C	200	0.151	58.762	44.071
STORAGE TEMPERATURE	-40°C~85°C	150	0.191	46.304	34.728

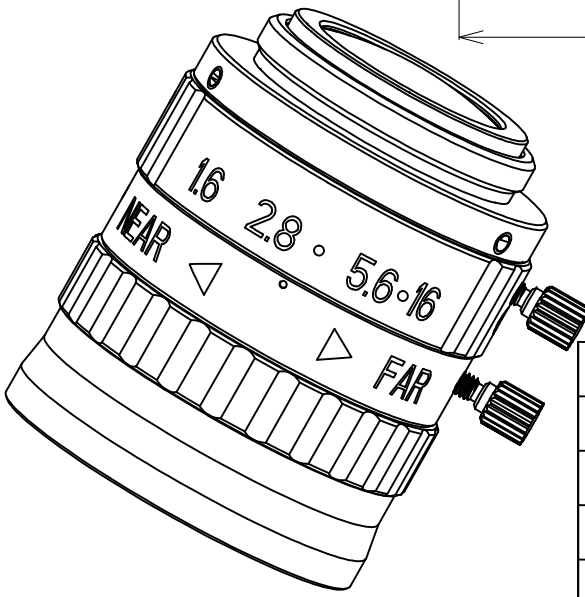

Common Tolerance	④					
Angle	±0.5°	③				
0.000	±0.01	②				
0.00	±0.03	①				
0.0	±0.05	Rev	Description	Name	Date	
0	±0.1		Design	Examine	Checked	Approved

Material:	
3RD_ANGLE_PROJN	
Unit	mm
Scale	2:1
Ver	00
Date	2018.10.10

<b>Cnomax Vision</b>
Model:
<b>三分之二英寸35MM-5M</b>
Part Name:
<b>CNV355M</b>
Dwg No: