

RoHS HF REACH

2/3" F1.6/25MM /5MEGA/C MOUNT	
FOCAL LENGTH	f=25MM
F.NO	F=1:1.6--16
FOCUS DISTANCE	0.1M--1.5M
FLANGE BACK	17.526MM IN AIR
BACK FOCUS	10.45MM IN AIR
FILTER SCREW SIZE	M30.5*P0.5
MOUNT	C
REL. ILLUMINATION	≥76%
CHIEF RAY ANGLE	<7°

调焦固定螺丝 (整周2个)

光栏调节固定螺丝 (整周2个)

像面

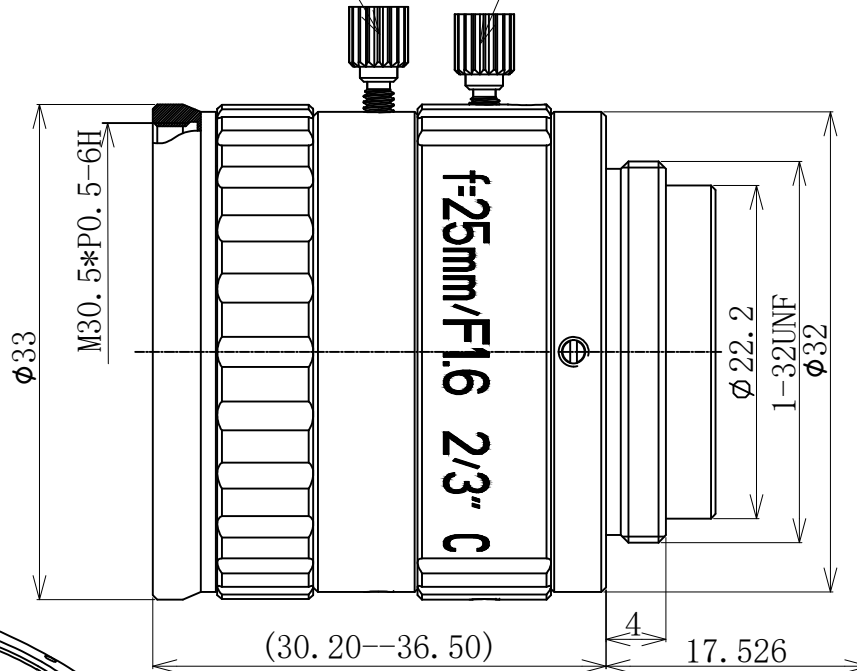

FIELD OF VIEW	SENSOR	2/3"	1/2"
	D	23.3°	17.1°
	H	18.7°	13.7°
	V	14.1°	10.3°
TV DISTORTION	<0.1%		<0.05%

WORKING DISTANCE	OPTICAL MAGNIFICATION	2/3" FIELD OF VIEW			
MM		H	V		
900	0.028	312.47	234.35		
800	0.032	277.92	208.44		
700	0.036	243.37	182.53		
650	0.039	226.09	169.57		
600	0.042	208.82	156.61		
550	0.046	191.54	143.66		
500	0.051	174.26	130.7		
450	0.057	156.98	117.73		
400	0.064	139.69	104.77		
350	0.073	122.41	91.805		
300	0.085	105.11	78.835		
250	0.102	87.811	65.859		
200	0.127	70.496	52.872		
WORKING TEMPERATURE	-40°C~80°C	150	0.168	53.155	39.866
STORAGE TEMPERATURE	-40°C~85°C	100	0.25	35.758	26.819

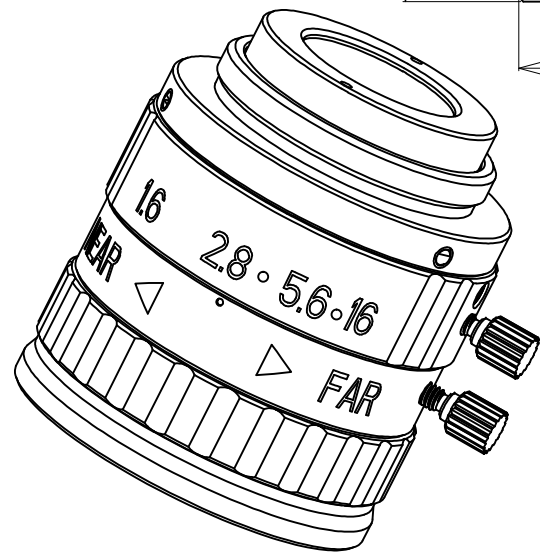

外观标准	60--40	200	0.127	70.496	52.872
WORKING TEMPERATURE	-40°C~80°C	150	0.168	53.155	39.866
STORAGE TEMPERATURE	-40°C~85°C	100	0.25	35.758	26.819

Common Tolerance		④					
Angle		±0.5°	③				
0.000		±0.01	②				
0.00		±0.03	①				
0.0		±0.05	Rev	Description	Name	Date	
0		±0.1		Design	Examine	Checked	Approved

Material:		
3RD_ANGLE_PROJN		
Unit	mm	
Scale	2:1	
Ver	00	
Date	2018.03.01	

Cnomax Vision	
Model:	
三分之二英寸25MM-5M	
Part Name:	
CNV255M	
Dwg No:	