

RoHS HF REACH

1.1" F2.4/50MM /20MEGA/C MOUNT

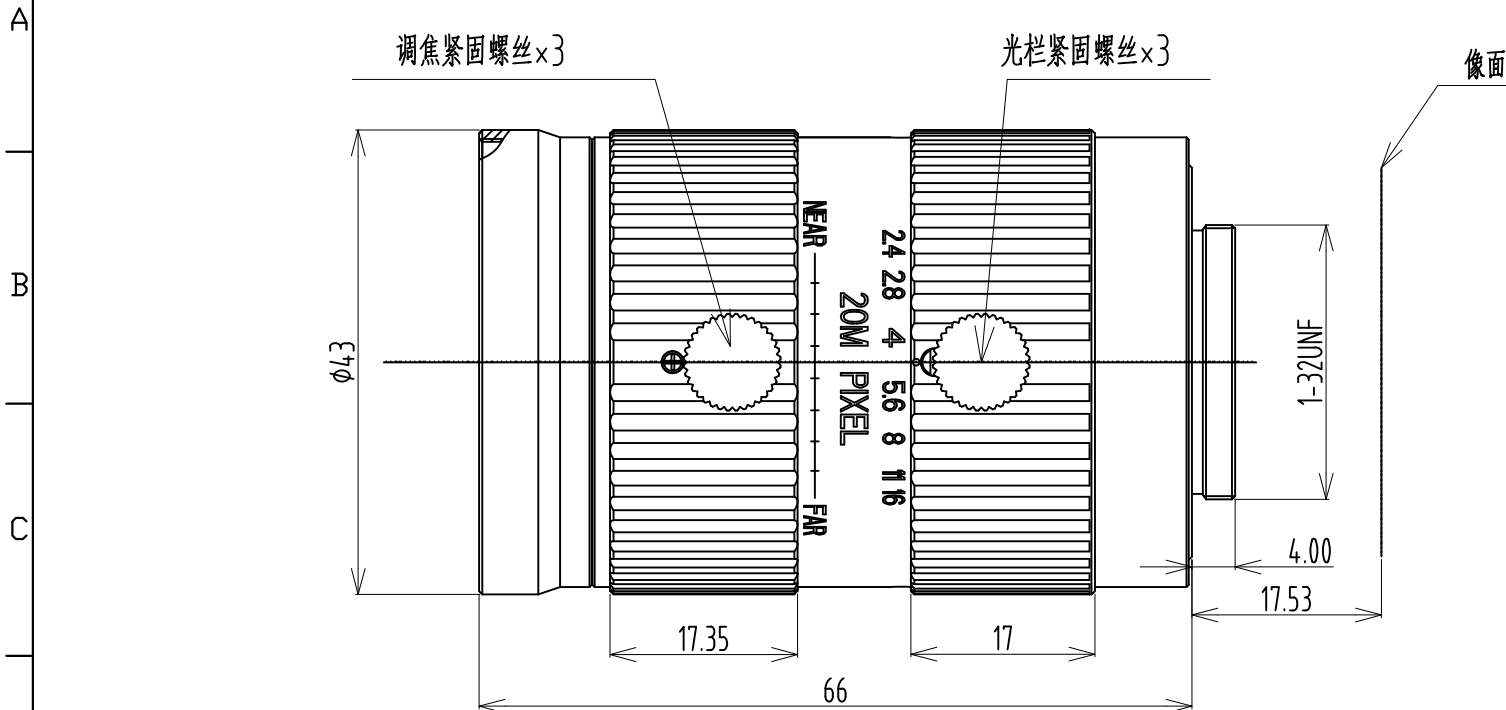

| | | | | |
|--------------------------|--------------------|--------|--------|-------|
| FOCAL LENGTH | f=50MM | | | |
| F.NO | F=1:2.4--16 | | | |
| FOCUS DISTANCE | 0.3M--无穷远 | | | |
| FLANGE BACK | 17.526MM IN AIR | | | |
| BACK FOCUS | 30 | | | |
| FILTER SCREW SIZE | M40.5*P0.5 | | | |
| MOUNT | C | | | |
| REL. ILLUMINATION | ≥70% | | | |
| Front/Rear Effective Dia | Front φ26 Rear φ18 | | | |
| FIELD OF VIEW WD=500 | SENSOR | 1.1" | 1" | 2/3" |
| | D | 19.3° | 17.6° | 12.1° |
| | H | 15.5° | 14.1° | 9.7° |
| V | 11.6° | 10.5° | 7.2° | |
| TV DISTORTION | <0.1% | <0.08% | <0.05% | |

| | | | |
|------------------|-----------------------|--------------------|---------|
| WORKING DISTANCE | OPTICAL MAGNIFICATION | 1.1" FIELD OF VIEW | |
| MM | | H | V |
| 2000 | 0.023X | 612.992 | 459.691 |
| 1800 | 0.026X | 550.524 | 412.893 |
| 1500 | 0.031X | 456.940 | 342.076 |
| 1000 | 0.047X | 301.024 | 225.768 |
| 900 | 0.052X | 269.859 | 202.394 |
| 800 | 0.059X | 238.704 | 179.028 |
| 700 | 0.068X | 207.566 | 155.674 |
| 600 | 0.08X | 176.449 | 132.336 |
| 550 | 0.088X | 160.902 | 120.677 |
| 500 | 0.097X | 145.367 | 109.025 |
| 450 | 0.109X | 129.845 | 97.384 |
| 400 | 0.123X | 114.34 | 85.755 |
| 350 | 0.143X | 98.86 | 74.145 |
| 300 | 0.169X | 83.42 | 62.565 |

| | |
|---------------------|------------|
| 外观标准 | 60--40 |
| WORKING TEMPERATURE | -40°C~80°C |
| STORAGE TEMPERATURE | -40°C~85°C |

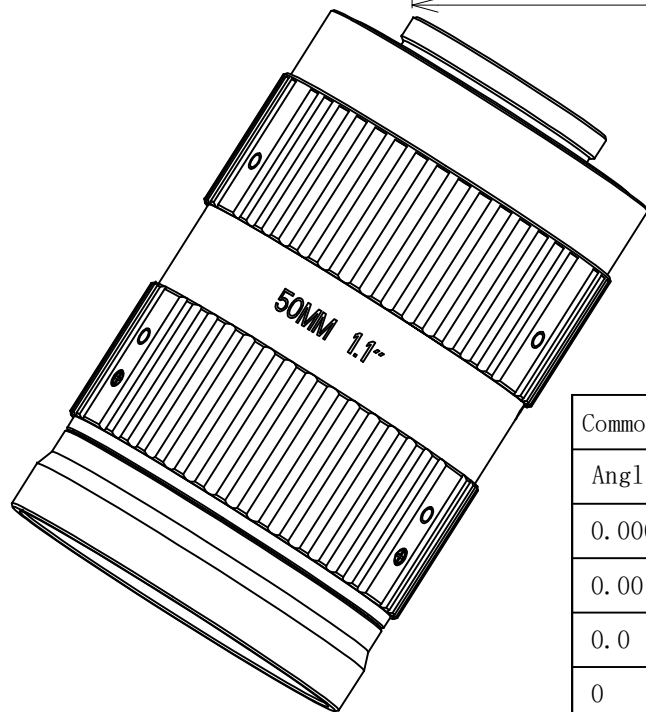

| | | | | | |
|------------------|-------|--------|-------------|---------|----------|
| Common Tolerance | ④ | | | | |
| Angle | ±0.5° | ③ | | | |
| 0.000 | ±0.01 | ② | | | |
| 0.00 | ±0.03 | ① | | | |
| 0.0 | ±0.05 | Rev | Description | Name | Date |
| 0 | ±0.1 | Design | Examine | Checked | Approved |

| | |
|-----------------|------------|
| Material: | / |
| 3RD_ANGLE_PROJN | |
| Unit | mm |
| Scale | 2:1 |
| Ver | 00 |
| Date | 2018.09.18 |

| | |
|----------------------|-----------------------|
| Cnomax Vision | |
| Model: | 50MM-1.1"-20M-C MOUNT |
| Part Name: | CNV5020M |
| Dwg No: | |